



Modular Cooking Range Line 700XP Full Module Electric Fry Top, Chromium Plated

ITEM # _____

MODEL # _____

NAME # _____

SIS # _____

AIA # _____



371194 - 371197 - 371201

Short Form Specification

Item No. _____

To be installed on open base installations or bridging supports. Smooth cooking surface in chromium-plated mild steel. Temperature range from 110°C to 280°C. Removable drawer below the cooking surface for the collection of grease and fat. Exterior panels in stainless steel with Scotch Brite finish. One piece pressed work top in 1.5 mm thick stainless steel. Right-angled side edges to allow flush-fitting junction between units.

Main Features

- Unit to be mounted on open base cupboards, bridging supports or cantilever systems.
- Large drain hole on cooking surface permits the draining of fat into large 1,5 liter collector placed under the cooking surface.
- Large grease collection container available as optional accessory to be installed under top units over open base cupboard.
- Safety thermostat and thermostatic control.
- Stainless steel high splash guard on the rear and sides of cooking surface. Splash guard can be easily removed for cleaning.
- IPX 4 water protection.
- Infrared heating elements mounted below the cooking surface.
- Frontal simmering zone.
- [NOT TRANSLATED]
- [NOT TRANSLATED]
- [NOT TRANSLATED]

Construction

- All exterior panels in Stainless Steel with Scotch Brite finishing.
- One piece pressed 1.5 mm work top in Stainless steel.
- Model has right-angled side edges to allow flush fitting joints between units, eliminating gaps and possible dirt traps.
- Cooking surface to be completely smooth. (only for 371194)
- [NOT TRANSLATED]
- Cooking surface to be 2/3 smooth and 1/3 ribbed. (not for 371194)

Included Accessories

- 1 of Scraper for smooth plate fry tops PNC 164255
- 1 of SCRAPER FOR RIBB PLATE FRY TOP (not for 371194) PNC 206420

Optional Accessories

- Scraper for smooth plate fry tops PNC 164255
- Junction sealing kit PNC 206086
- Support for bridge type installation, 800mm PNC 206137
- Support for bridge type installation, 1000mm PNC 206138
- Support for bridge type installation, 1200mm PNC 206139

APPROVAL: _____



Experience the Excellence
www.electroluxprofessional.com
professional@electrolux.com

- Support for bridge type installation, 1400mm PNC 206140
- Support for bridge type installation, 1600mm PNC 206141
- Chimney upstand, 800mm PNC 206304
- Right and left side handrails PNC 206307
- Back handrail 800mm, Marine PNC 206308
- Grease/oil kit container for 700 line frytops (half and module) and 900 line frytops (module) PNC 206346
- Chimney grid net, 400mm (700XP/900) PNC 206400
- SCRAPER FOR RIBB PLATE FRY TOP (not for 371194) PNC 206420
- - NOT TRANSLATED - PNC 206455
- Frontal handrail, 800mm PNC 216047
- Frontal handrail, 1200mm PNC 216049
- Frontal handrail, 1600mm PNC 216050
- Large handrail - portioning shelf, 800mm PNC 216186
- 2 side covering panels for top appliances PNC 216277

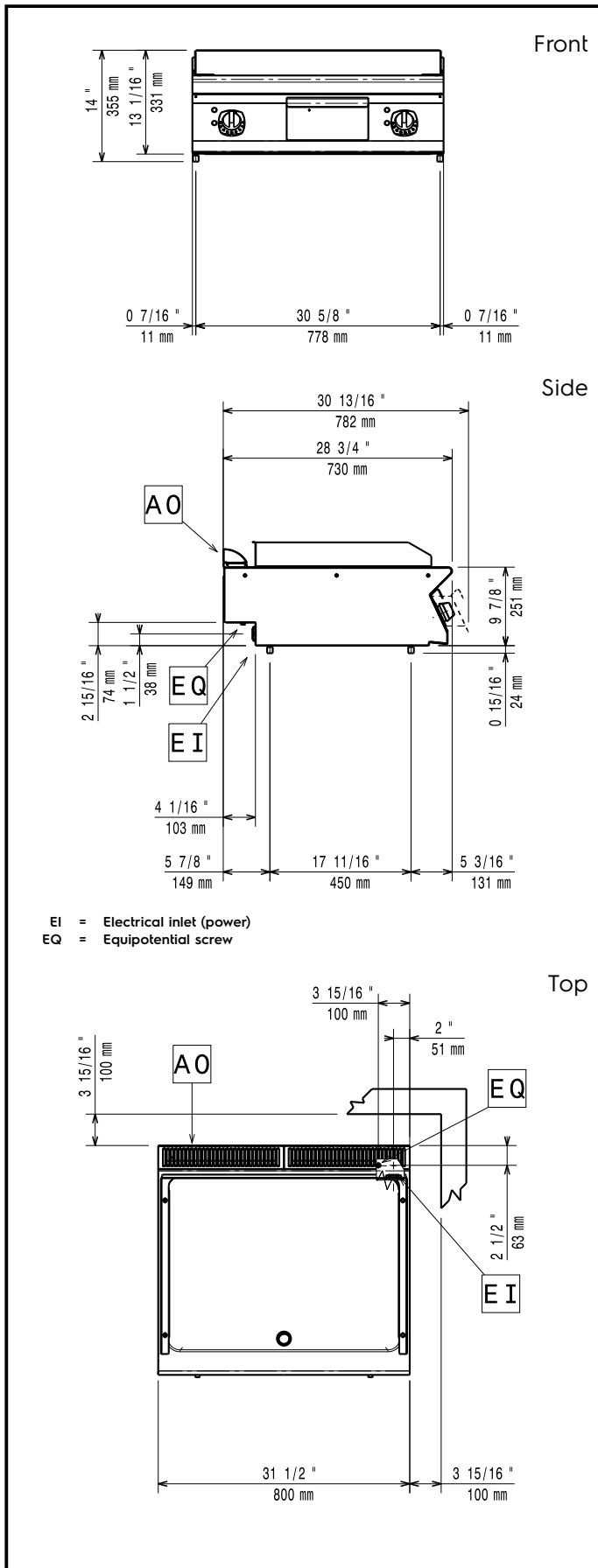

Electric

Supply voltage:

371194 (E7FTEHCSI0)	400 V/3 ph/50/60 Hz
371197 (E7FTEHCPI0)	400 V/3 ph/50/60 Hz
371201 (E7FTEHCPIN)	230 V/3 ph/50/60 Hz

Electrical power max.:

371194 (E7FTEHCSI0)	8.4 kW
371197 (E7FTEHCPI0)	8.4 kW
371201 (E7FTEHCPIN)	7.8 kW

Total Watts:

371194 (E7FTEHCSI0)	8.4 kW
371197 (E7FTEHCPI0)	8.4 kW
371201 (E7FTEHCPIN)	7.8 kW

Key Information:

Cooking surface width:	730 mm
Cooking surface depth:	540 mm
Working Temperature MIN:	120 °C
Working Temperature MAX:	280 °C
External dimensions, Width:	800 mm
External dimensions, Depth:	730 mm
External dimensions, Height:	250 mm
Net weight:	70 kg

Shipping weight:

371194 (E7FTEHCSI0)	74 kg
371197 (E7FTEHCPI0)	73 kg
371201 (E7FTEHCPIN)	84 kg

Shipping height:

371194 (E7FTEHCSI0)	520 mm
371197 (E7FTEHCPI0)	520 mm
371201 (E7FTEHCPIN)	540 mm

Shipping width:

820 mm

Shipping depth:

860 mm

Shipping volume:

371194 (E7FTEHCSI0) 0.37 m³

371197 (E7FTEHCPI0) 0.37 m³

371201 (E7FTEHCPIN) 0.38 m³

If appliance is set up or next to or against temperature sensitive furniture or similar, a safety gap of approximately 150 mm should be maintained or some form of heat insulation fitted.

[NOT TRANSLATED]

371194 (E7FTEHCSI0) EFT72

371197 (E7FTEHCPI0) EFT72

371201 (E7FTEHCPIN) N7RE1